



Technical Assistance  
Study for the Ventilation  
Units Product Group

DRAFT VERSION 13 NOVEMBER 2015

**FREQUENTLY ASKED QUESTIONS**

**TO**

**COMMISSION REGULATION (EU) No 1253/2014**

**of 7 July 2014**

**implementing Directive 2009/125/EC of the European Parliament and of the Council with regard to  
ecodesign requirements for ventilation units (Text with EEA relevance)**

**and**

**DELEGATED COMMISSION REGULATION (EU) No 1254/2014**

**of 11 July 2014**

**supplementing Directive 2010/30/EU of the European Parliament and of the Council with regard to  
energy labelling of residential ventilation units**

## INTRODUCTION

The Ecodesign and Energy Labelling regulations for ventilation units were published in 2014. The regulations establish minimum requirements and an energy labelling scheme for the products in their scope. These guidelines aim to help relevant stakeholders, including industry and public authorities, to implement the Regulations in practice. They summarise the most relevant information from the regulations to give SMEs an introduction to the subject matter and answer the most common questions. The guidelines are intended to be used only for facilitating the implementation of the Regulations. They are not intended to replace the Regulations or to provide “interpretation” beyond their intent. The guidelines only reflect the opinion of the Commission services and are not legally binding. A finally binding legal interpretation of EU legislation may only be provided by the European Court of Justice. The guidelines are without prejudice to the position the Commission might take should an issue arise in a procedure before the European Court of Justice.

## FREQUENTLY ASKED QUESTIONS

### QUESTION ON THE PLACING ON THE MARKET – PUTTING INTO SERVICE

**1. What is it exactly meant for placing a product on the market? What is the difference with putting it into service?**

For the definitions of "placing on the market" and "putting into service", please refer to the Ecodesign Directive 2009/125, in particular Article 2. Further explanations can be found in the "Blue Guide"<sup>1</sup>, in particular under sections 2.2. and 2.3, according to which placing a product on the market refers to making it available for the first time on the Union market. The operation is reserved either for a manufacturer or an importer i.e. the manufacturer and the importer are the only economic operators who place products on the market. A product is made available on the market when supplied for distribution, consumption or use on the Union market in the course of a commercial activity, whether in return for payment or free of charge.

Concerning the differences between "placing on the market" and "putting into service", please refer to the *Frequently Asked Questions (FAQ) on the Ecodesign Directive and its Implementing Regulations*<sup>2</sup>, question 1 pg3.

### QUESTIONS ON THE PLACING ON THE MARKET – SPECIFIC CASES

**2. Would a company be able to manufacture non-compliant products after 01/01/2016, if an order before 31/12/2015 is received? What happens to non-compliant products which fail after 01/01/2016, but are still in their warranty period? Does Regulation 1253/2014 apply to ventilation units, to be installed in buildings which are already under construction on the day this Regulation entered into force?**

As a general rule, it is the moment when a product is placed on the market which determines the applicable legal requirements. Products placed on the market after the date an Ecodesign Regulation is applicable

<sup>1</sup>Available at <http://ec.europa.eu/DocsRoom/documents/11502>

<sup>2</sup> Available at [http://ec.europa.eu/growth/industry/sustainability/ecodesign/policy-actions/index\\_en.htm](http://ec.europa.eu/growth/industry/sustainability/ecodesign/policy-actions/index_en.htm)

(1253/2014, in our specific case), need to comply with its provisions. Moreover, any private contract needs to respect the applicable legal framework. The placing on the market takes place when the product is supplied for distribution, consumption or use and it is in any event necessary that the product has been manufactured and its conformity has been assessed. A contract which has been signed to manufacture a particular product, where this product still does not exist, cannot be construed as placing on the market. Therefore, the Regulation 1253/2014 cannot be interpreted as excluding from its scope products in the situations hereby described.

### QUESTIONS ON "SEPARATE DELIVERY" AND CE-MARKING

- 3. Who is responsible for the CE marking when the ventilation unit is delivered without control system? The manufacturer of the ventilation unit, or the one who connects the control system? How to label a RVU sold without control system? How to deal with partly delivered (separate components) and/or installed units?**

It is not fully clear by the expression "control system", if the "indoor climate control system" is meant, or the "motor control system". The first one is e.g. related, for RVUs, to the choice of the control factor, (Annex IV-1-n of Regulation 1253/2014), whereas the second one is related to the declared type of drive (Annex IV-1-e (for RVUs) or Annex V-1-d (for NRVUs)). Specific categories of drive are explicitly addressed by the Ecodesign Regulation 1253/2014: as an effect of the provisions laid down in annex II for RVUs and Annex III for NRVUs, ventilation units have to be equipped with a multi-speed drive or variable speed drive. In case it is opted for the variable speed drive (VSD), as from definition 4 of Annex I (of Regulation 2531/2014), the VSD can be a separate delivery. Concerning the "indoor climate control systems", specifically for RVUs, several options are possible (e.g. "manual control", "demand control", etc.).

If a ventilation unit is placed on the market without the "indoor climate control system" or the "motor control system", the manufacturer has to provide the information on which system has to be installed on the ventilation unit, so that it complies with the requirements when putting it into service.

The manufacturer has to CE-mark the product showing he has complied with all his obligations. The installer is responsible for ensuring that the product is put into service in accordance with the information provided by the manufacturer pursuant to Annex IV or V. Suppliers also need to supply an energy label when placing residential ventilation units on the market, even if without indoor climate control system(s), in which case the calculation of the label class needs to take into account the information provided by the manufacturer pursuant to Annex IV-1-n of the ecodesign regulation.

Where other components might be delivered separately, an approach similar to the abovementioned situation can be adopted.

- 4. Allegedly, there are some third countries (outside the EU) which require, to products to be sold on their markets, compliance with some EU directives, e.g. the Machinery directive. Some ventilation units can be in scope to the machinery directive, but they are also impacted by a specific ecodesign regulation (Reg. 1253/2014). Therefore, to affix the CE mark the manufacturer shall assess compliance of the product with the requirements of these two directives<sup>3</sup>. With this said, the question**

---

<sup>3</sup> To simplify, the question is posed without considering other EU directives which can impact on these products

**is as follows: when selling the product outside of EU, these manufacturers want to know if they can affix a kind of "partial CE mark", i.e. a CE mark only showing compliance with the Machinery directive (and not with Ecodesign Reg. 1253/2014). Is this possible?**

The fact that the CE marking is affixed on a product that is placed on the market of a non-EU/EEA market shall not change its meaning, and this is to indicate conformity with all the requirements laid down by the EU harmonisation legislation in question.

Please note that further Q&As on ventilation units are also present in the *Frequently Asked Questions (FAQ) on the Ecodesign Directive and its Implementing Regulations*<sup>4</sup>, pp71-72.

## QUESTIONS ON ARTICLE 1 - SUBJECT MATTER AND SCOPE (NO 1253/2014)

### 5. Under what operating conditions, flow/pressure difference, is the electric power input determined?

The electric power input is measured at the declared maximum flowrate and the pressure difference related to the maximum flowrate. For BVUs, the total electric power input is the sum of the electric power input measured per individual fan including controllers but without frost protection. Accordingly, the '30 W per air stream', cf. Article 1 (b), means that the Regulations shall not apply to BVUs with a total electric power input of less than 60 W except for information requirements. The limit of '30 W per air stream' also applies to alternating BVUs. *For maximum flowrate, see the question: 'What is the flowrate (maximum, reference or nominal) for an alternating BVU?'*

Electric power input is:

- **not** power in the Best Efficiency Point (BEP) according EU 327/2011 (Fan Regulation);
- **not** maximum power written on the name plate of the fan within the unit; and
- **not** always the same as the power on the name plate of the entire unit, because this may also include the power of additional components like pre- and after-heater etc.

### 6. What is meant by 'toxic, highly corrosive or flammable or in environments with abrasive substances', Article 1 (f), (v)?

- '*toxic, highly corrosive or flammable*' refers to those environments where the handling of toxic, highly corrosive or flammable gases or vapours takes place as set out in Regulation (EC) No 1272/2008<sup>5</sup> and its adaptations;
- '*in environments with abrasive substances*' can be considered to be in line with the FAQ for Regulation (EU) No 327/2011.

### 7. How to deal with units combining multiple functions of which some might be regulated by other Ecodesign Regulations?

**For NRVUs** a distinction is made between ventilation components and additional non-ventilation components. Additional non-ventilation components can be heating or cooling coils that are not part of

<sup>4</sup> Available at [http://ec.europa.eu/growth/industry/sustainability/ecodesign/policy-actions/index\\_en.htm](http://ec.europa.eu/growth/industry/sustainability/ecodesign/policy-actions/index_en.htm)

<sup>5</sup> OJ L 353, 31.12.2008, p. 1.

the reference configuration and therefore corrected for in the calculation of  $SFP_{int}$ . Ventilation-components include for a BVU among others a HRS. If this is combined with a heat pump for heat recovery, the BVU does **not** fall under the Ventilation Unit Regulation. However, if an air-to-water heat pump uses exhaust air from the ventilation unit by using a coil (additional non-ventilation component not affecting heat recovery), the ventilation unit falls under the Ventilation Unit Regulation. The air-to-water heat pump must comply with the relevant Ecodesign Regulation as well. Examples of such products are shown in Figure 1.

*Figure 1: Examples of NRVUs within scope using a coil (additional non-ventilation component not affecting heat recovery) to connect to an air-to-water heat pump*

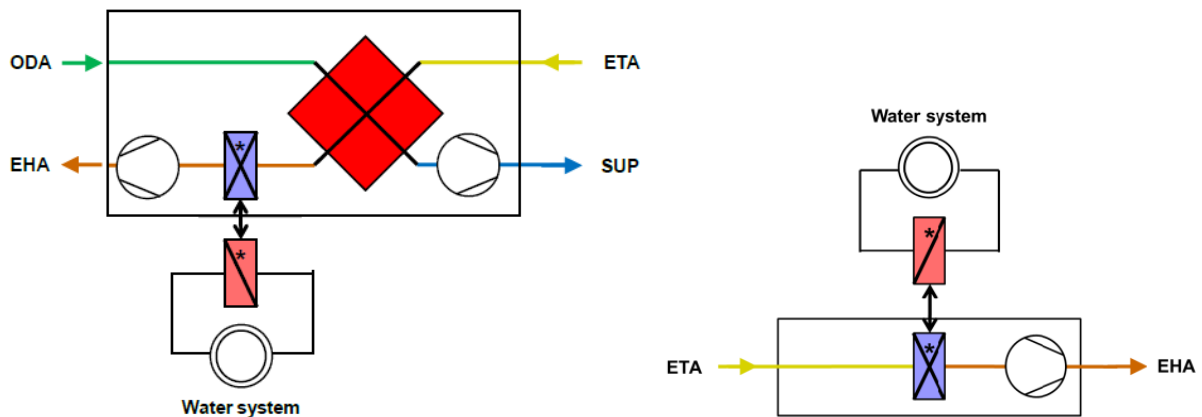

**Concerning RVUs**, it is considered that BVUs equipped with a heat pump for heat recovery only (same as 'heat transfer being additional to heat recovery') do **not** fall under the Ventilation Unit Regulation. Figure 2 shows examples of such products

*Figure 2: Examples of BVUs outside scope with a heat pump for heat recovery only (same as 'heat transfer being additional to heat recovery')*

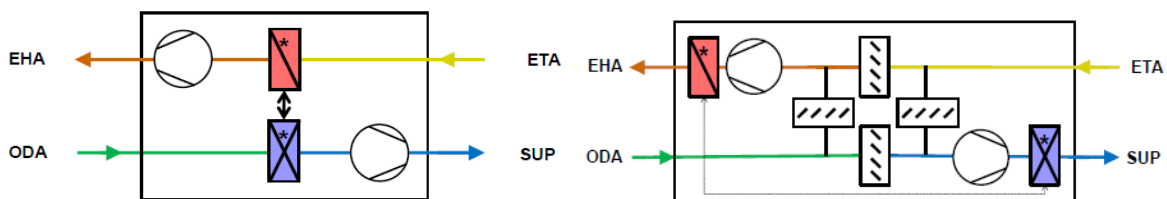

RVU multifunctional products/systems, such as UVU including exhaust air-to-water heat pumps, do **not** fall under the Ventilation Unit Regulation **as long as** the component(s) that constitutes a ventilation unit is integrated into the rest of the system and is not commercialised/delivered separately. As an example, if the ventilation unit is delivered separately (able to operate) and it is up to the final user to potentially integrate it with the heat pump, this ventilation unit will be compliant with the Ventilation Unit Regulation).

The unit's main function may be heating or cooling (or water heater function). In this case, the product must fulfil other relevant Ecodesign Regulations, if this is the case.

## 8. Are professional range hoods in scope to Regulation 1253/2014?

It is intended that professional range hoods will **not** be within the scope of Regulation 1253/2014. However, where a ventilation unit can be used occasionally and for a limited time, also for evacuating fumes and odours from cooking, such a ventilation unit still falls under Regulation 1253/2014.

## QUESTIONS ON ARTICLE 2 - DEFINITIONS (NO 1253/2014)

### 9. We manufacture VUs for marine/cruise ship applications. Are they within scope?

Article 2 (1) says ‘ventilation unit (VU)’ means an electricity driven appliance equipped with at least one impeller, one motor and a casing and intended to replace utilized air by outdoor air **in a building or a part of a building**;

Article 1 (3) of the Ecodesign Directive 2009/125/EC stipulates that the Directive does not apply to means of transport for persons or goods.

It follows that an implementing Regulation should **not** apply to products that are designed **only** for use in e.g. marine ships. However, if the same product is designed for use in a means of transport for persons or goods **and** for use in a building, it should comply with all relevant requirements of the Ecodesign measure (bearing in mind the exclusions of scope of the regulation itself).

### 10. What is meant by ‘to replace utilised air by outdoor air’

Article 2 (1) says ‘ventilation unit (VU)’ means an electricity driven appliance equipped with at least one impeller, one motor and a casing and intended **to replace utilised air by outdoor air** in a building or a part of a building;

In a building or part of a building designed for human occupancy, the purpose of the ventilation unit is to replace utilised air by outdoor air. In this respect, the utilised air is the polluted air due to the presence of human beings and their use of the building including emissions from materials, equipment, internal and external heat gains. The Regulation should **not** apply to a product intended to be used in a building or part of a building **not** designed for human occupancy or to a product that is **not** intended, as its primary function, to replace utilised air (as specified above), unless the **same** product is also designed to **only** replace utilised air (as specified above) and thus, should comply with all relevant requirements of the ecodesign measure (bearing in mind the exclusions of scope of the Regulation itself).

An example of an application where the Regulation should not apply are ‘Data centres’.

### 11. Are products designed for 100% recirculation considered ventilation units?

If the product is **not** designed for replacing utilised air with outdoor air, it is **not** a ventilation unit, unless the **same** product is also designed to replace **only** utilised air, and thus it should comply with all relevant requirements of the ecodesign measure (bearing in mind the exclusions of scope of the Regulation itself). In case the product has a connection to the outdoor with a supply/exhaust air flowrate in regular operation of minimum 10% of the total declared recirculated air flowrate, the unit is considered a

ventilation unit and falls under the Ventilation Unit Regulation. This implies that it must comply with all relevant requirements of the Ecodesign measure at that supply/exhaust flowrate, e.g., requirements concerning SFPint/etav\_nrvu/HRS.

**12. We manufacture ventilation equipment for ‘cleanrooms’. Cleanrooms can be found in hospitals, research centers, pharmaceutical and certain other manufacturing plants. The ventilation units used for clean rooms treat large volumes of air, with very limited replacement of the treated air by new air. One objective is to ensure overpressure in the cleanrooms so that the level of pollutants (dust,microbes...) is kept at minimal or controlled. Are they within scope?**

As long as:

1. These products can be defined as ventilation units, in line with definition 1 of article2 of the Ecodesign Regulation on Ventilationunits, i.e."an electricity driven appliance.....intended to replace air by outdoor air in a building")
2. These products are not between the scope exclusions.

They fall in scope to the Ecodesign (and Energy Labelling, if RVUs) regulation.

**13. What is a ‘housing’ in terms of Regulation 327/2011, and what is a ‘casing’ in terms of Regulation No. 1253/2014 and Delegated Regulation No. 1254/2014?**

‘The Regulation shall not apply to ventilation units which are axial or centrifugal fans only equipped with a housing in terms of Regulation (EU) No. 327/2011’, Article 1 (c). This implies, that such products are considered ‘fans’ and shall be treated according to (EU) No. 327/2011.

A working draft from CEN TC 156 WG 17 ‘*Fans – Procedures and methods to determine the energy efficiency for the electrical input power range of 125 W up to 500 kW – Complementary element*’ describes the term housing in detail as a casing around the impeller that guides the gas stream towards, trough and from the impeller. The housing may include an inlet bell, an inlet guide vane, an outlet guide vane or an outlet diffuser. For examples of boundaries for different fan types (in line with the draft working document), see sketches (a) to (f) in Figure 3. A fan can be with or without housing. Protective guards are not included in the measurements of fans (are removed for testing).

Ventilation units are by definition equipped with a casing, Article 2 (1), which, according to the above, is additional to the housing in terms of Regulation (EU) No. 327/2011. This implies the casing is defined as all parts of the ventilation unit additional to the housing that interfere with the airflow. For a ventilation unit including a fan without housing, there will only be the casing interfering with the airflow. Products that would normally be called ‘box-fans’ or ‘roof-fans’ are ventilation units. For examples of ventilation units, see sketches (g) and (h) in Figure 3.

Figure 3: Sketches of some fan types and ventilation unit types with indication of 'housing' and 'casing'

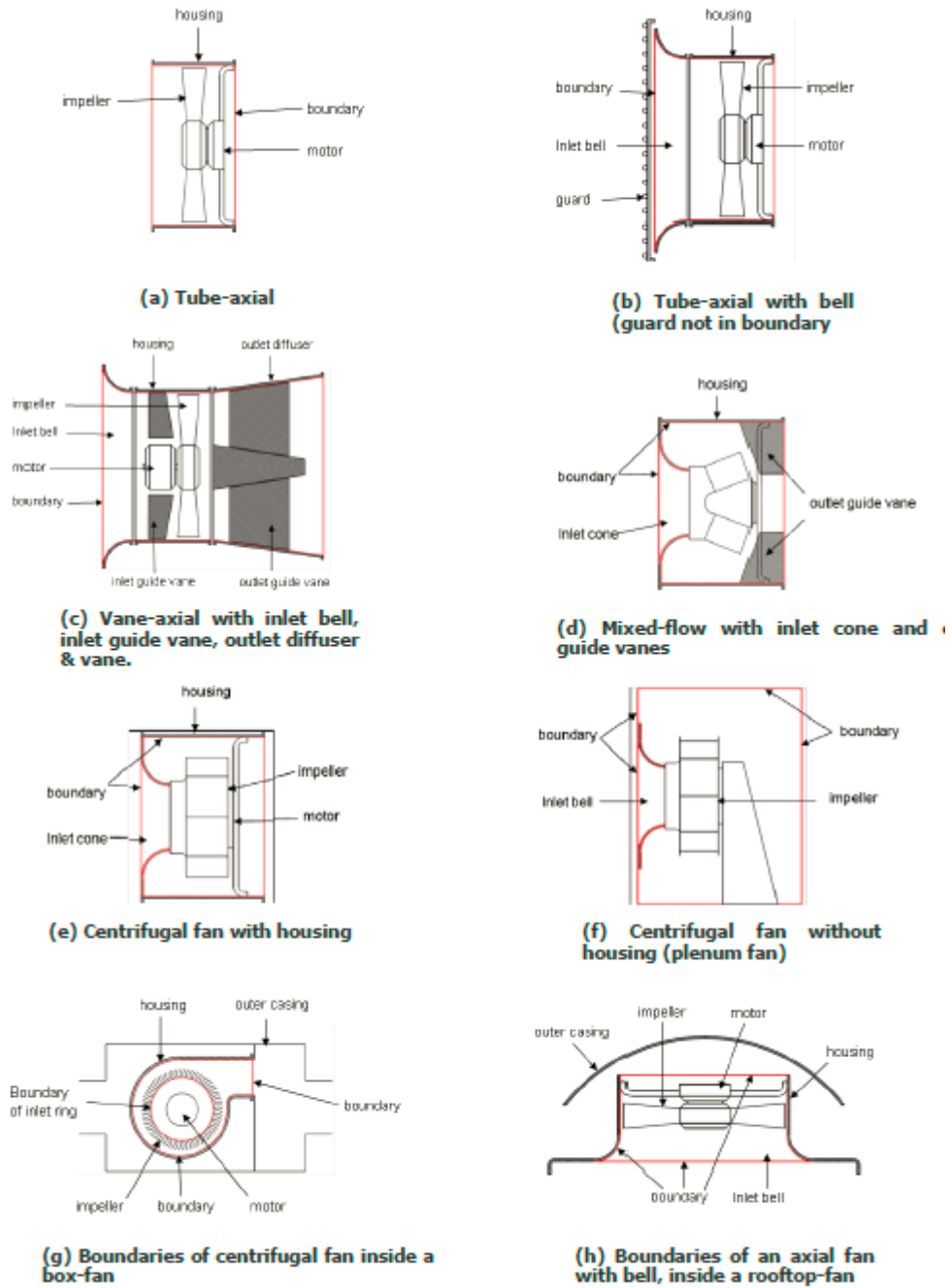



**14. According to which conditions/parameters shall a ventilation unit be declared a 'non-residential ventilation unit' (NRVU) or a 'residential ventilation unit' (RVU)?**

Definitions 2 and 3 of Article 2 of Regulation 1253/2014 give the necessary information in reply to this question. The following table summarises the information.

Maximum flowrate $\leq 250$ m <sup>3</sup> /h	250 m <sup>3</sup> /h < maximum flowrate < 1000 m <sup>3</sup> /h	Maximum flowrate $\geq 1000$ m <sup>3</sup> /h
RVU	RVU (if the manufacturer <b>declares</b> the ventilation unit's intended use as being exclusively for a residential ventilation application)	NRVU
	NRVU (if the manufacturer <b>does not declare</b> the ventilation unit's intended use as being exclusively for a residential ventilation application)	

Note: For NRVUs, the maximum flowrate and corresponding external pressure are declared (chosen) by the manufacturer (i.e., there are no lower pressure requirements). Thus, the same ventilation unit design can for a maximum flowrate  $250 \text{ m}^3/\text{h} < \text{maximum flowrate} < 1000 \text{ m}^3/\text{h}$  either be declared as a NRVU with a higher air flowrate and lower corresponding pressure (maximum flowrate at a pressure under  $100/50\text{Pa}^*$ ) or as a RVU (maximum flowrate at  $100/50\text{Pa}^*$ ). Figure 4 shows this graphically. ‘\*’ *100/50Pa* refers to question: ‘What is the maximum flowrate for a ducted RVU that is not able to deliver  $100 \text{ Pa}$ ?’

Figure 4: Example of a ventilation unit design that can either be declared as a NRVU or as a RVU

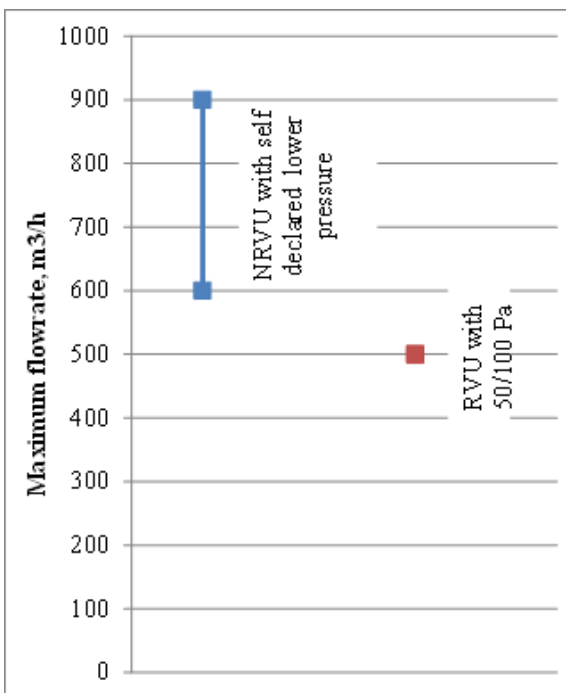

**15. What is the maximum flowrate for a ducted RVU that is not able to deliver 100 Pa?**

A ducted RVU must always be able to deliver 50 Pa as this defines the reference flowrate and the reference point for calculation of the SEC. In case the ducted RVU cannot deliver 100 Pa (Article 2, Definitions (4)), the maximum flowrate is determined at the maximum external static pressure difference that the ducted RVU can deliver (between 50 and 100 Pa).

For such a ducted RVU, the reference flowrate is the abscissa value to a point on a curve in the flowrate/pressure diagram which is at or closest to a reference point at  $100 \cdot \sqrt{\frac{50 \text{ Pa}}{P_{\max, \text{ext}, \text{stat}}}}$  % of the maximum flowrate, where  $P_{\max, \text{ext}, \text{stat}}$  is the maximum external static pressure difference (between 50 and 100 Pa).

*See further description in draft Commission communication DRAFT VERSION OF 06/11/2015, Section 4.1 'Determination of the reference and maximum flow for ducted RVUs'.*

**16. What is the reference flowrate for a non-ducted RVU**

For a non-ducted RVU the reference flow can be understood as the same as the maximum flow.

**17. What is the flowrate (maximum, reference or nominal) for an alternating BVU?**

In this type of unit, the exhaust airflow and supply airflow are sequential. Thus, the direction of the flow will change from exhaust to supply with a stop period in between. This must be taken in consideration and measured according to EN 13141.8 as described in draft Commission communication DRAFT VERSION OF 06/11/2015, Section 4.1, *Determination of the reference and maximum flow for ducted RVUs*

The airflow rate is the actual average flow rate over a cycle period as indicated by the grey area in Figure 5. In short, it is described as the mean value of the average measured airflow in first one direction (e.g., supply) and then in the other direction (extract), divided by two, where both airstreams are corrected according to the stop period.

*Figure 5: The airflow rate of alternating units*

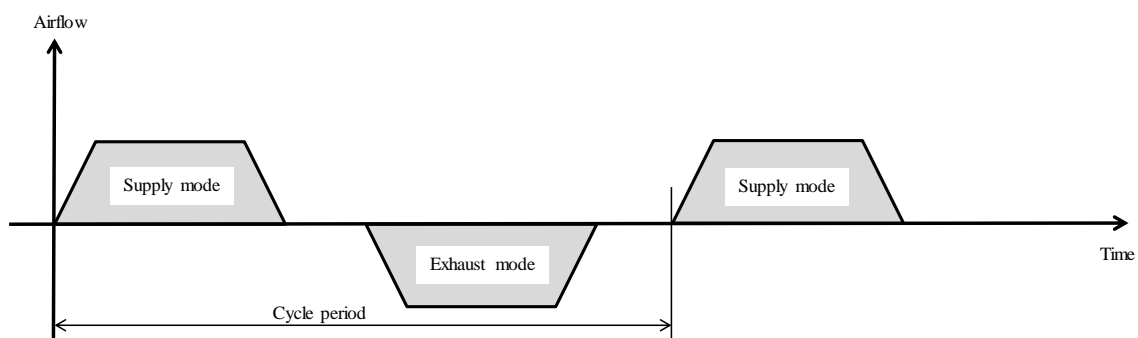

**18. What is the maximum flowrate for a non-ducted RVU that is not able to achieve 10 Pa?**

Article 2, Definitions, (4), states that the maximum flowrate is related to the airflow at the lowest achievable total pressure difference to be chosen from a set of values of 10 (minimum) -20-50-100-150-200-250 Pa, whichever is equal or just below the measured pressure difference value. In case a non-ducted RVU cannot deliver 10 Pa, the maximum flow is determined at the actual pressure and, according to the Regulation, the minimum pressure is declared '10 Pa' instead of the actual pressure (as in EN 13141-4 Section 3.5)

**QUESTIONS ON ANNEX I – DEFINITIONS (NO 1253/2014)**

**19. The Regulation describes a number of issues regarding fan efficiency for non-residential ventilation units (NRVUs). How is the fan efficiency of a NRVU defined and for what operational point must it fulfil the ecodesign requirements?**

For the calculation of internal specific fan power,  $SFP_{int}$ , where internal pressure measurements can be performed, the internal fan efficiency is to be used as defined and described in draft Commission communication DRAFT VERSION OF 06/11/2015 Section 5.2 (transitional method/prEN13053). Alternatively, with the use of the external fan efficiency for  $SFP_{int}$  determination for NRVU where internal pressure measurements cannot be performed as defined and described under Section 5.2 in draft Commission communication DRAFT VERSION OF 06/11/2015.

In case of UVUs, the Regulation distinguishes between UVUs in general and UVUs intended to be used with a filter. UVUs intended to be used with a filter must fulfil requirements concerning maximum internal specific fan power  $SFP_{int\_limit}$ .

All UVUs (both intended and not intended to be used with a filter) must fulfil the minimum fan efficiency of ventilation units,  $\eta_{v_u}$ . The fan efficiency of UVU is determined as described in draft Commission communication DRAFT VERSION OF 06/11/2015 at the declared (nominal) flow and pressure of the reference configuration. This implies that pressure losses due to the casing is taken into account. Please note that the operational point is not the best efficiency point of the fan but the nominal conditions of the ventilation unit as stated in Annex 1, 2 (2).

**20. Is one fan switched off a by-pass facility for bi-directional RVUs?**

One fan switched off during the summer (non-heating) can generally **not** be considered as a thermal by-pass facility. It is only accepted as a bypass facility if the air volume flow in by-pass mode is supported by supply/exhaust grills in the facade (openings) in analogy with UVU ventilation systems, and the information requirements for instructions to installation of these are followed as described in Annex IV (r).

**Central demand control:** For these types of units, the CTRL factor for central demand control (for the calculation of SEC) can only be used if these openings are also regulated by the control system of the units. The main fan(s) performance and opening(s) to be controlled according to the central demand.

**Local demand control:** For these types of units, the CTRL factor for local demand control (for the calculation of SEC) can only be used if these openings are also regulated by local demands by the control system of the unit. The main fan(s) performance and openings to be controlled according to local demands.

## QUESTIONS ON ANNEX V - INFORMATION REQUIREMENTS FOR NRVUs (NO 1253/2014)

### 21. How to declare a NRVU where the design point is not known at the time of placing the product on the market, e.g., in the case of mass produced NRVUs?

Mass-produced NRVUs are normally designed for a wide range of working points and are mostly produced in large quantities. Their capacity is generally given in ranges and they can optionally be used in different buildings and/or applications. Below we suggest an optional method on how to declare such products. Alternatively, the manufacturer can choose a specific working point and assess compliance with Regulation 1253/2014 with the standard approach.

#### Declaration of a mass-produced NRVU (optional)

If the working point is not specified by the customer, which can be the case for a mass-produced NRVU, the manufacturer can declare an area (graph) of nominal airflows with associated 'nominal external pressure ( $\Delta p_{s, ext}$ )', see Figure 6.

Figure 6: Example of declaration of a mass-produced VU

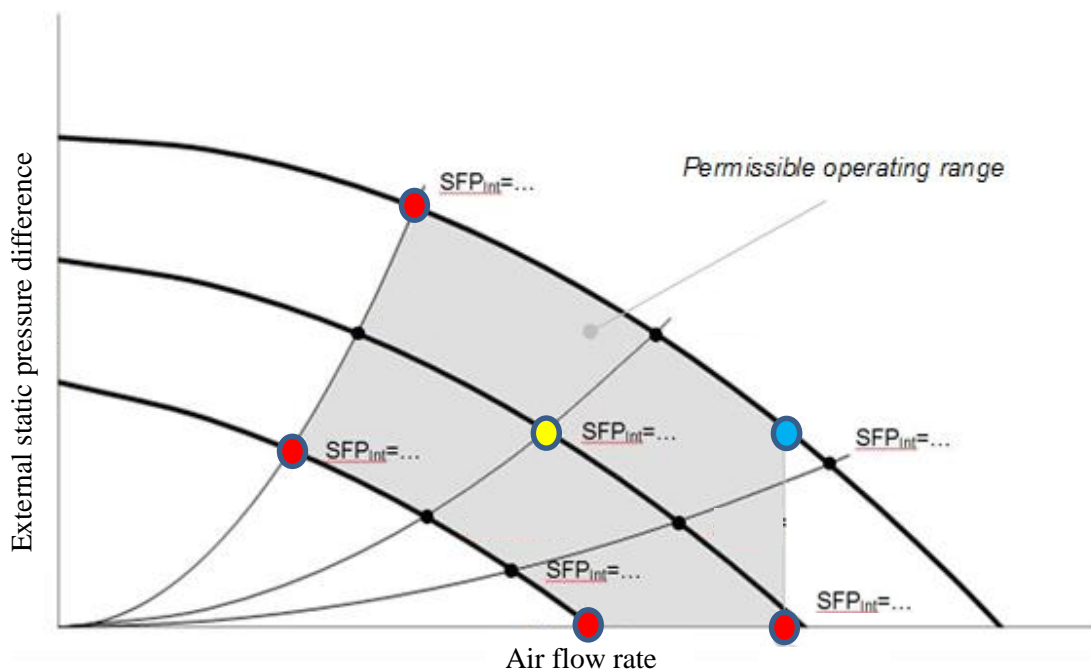

In this case, the declaration is as follows:

1. All values in Annex V in the Regulation (information requirements) for one nominal point within the grey area, with the largest flow and corresponding static pressure (indicated by the **blue dot** in Figure 5)
2. A graphical representation as above, containing at least five points where the outer limit is described in all cross sections (indicated by **red dots** in Figure 5) and an additional point **yellow dot** in the middle of the grey area, where the following values are indicated for each point:
  - a. Internal specific fan power of ventilation components (SFP<sub>int</sub>) and/or fan efficiency ( $\eta_{vU}$ ) regarding type of unit
  - b. Thermal efficiency of a non-residential HRS ( $\eta_{nrvu}$ ) (for BVU's only)
  - c. Sound power level (LWA)
  - d. Nominal flowrate ( $q_{nom}$ )
  - e. Nominal external pressure ( $\Delta p_{s, ext}$ )

The customer can use the NRVU if their operation point(s) (design working point(s) is within the declared area (grey area where the NRVUs comply with the minimum requirements).

The declaration as a mass produced product is optional, but all values with in the grey area must meet the requirements of the Regulation.

#### **QUESTIONS ON ANNEX IX – MEASUREMENTS AND CALCULATIONS (NO 1253/2014)**

##### **22. How can manufacturers handle filters, if they are different to the reference condition? Like a F9 filter instead of a F7 Filter?**

NRVUs must be tested and calculated in accordance with Annex IX of Regulation 1253/2014.

Specifically referring to the filters, where the tests are performed with a filter different from the ones foreseen in the reference configurations (see in particular definitions 3 and 4 in Annex I, Part 2), an appropriate (calculation) method must be used to infer the performance with the filter foreseen in the reference configurations.